



We have compiled all the key documents for this year’s challenge into one document. Source documents can be found at <http://www.firstlegoleague.org>

THIS IS ESSENTIAL INFORMATION AND SHOULD BE READ AND RE-READ BY EVERY MENTOR AND TEAM MEMBER. YOUR SUCCESS IS ALMOST ENTIRELY DEPENDENT ON YOUR COMPREHENSION OF THIS INFORMATION.

ALWAYS CHECK THE FAQ’S ON THE FIRST LEGO LEAGUE SITE. FAQ’S SUPERSEDE ALL INITIALLY PUBLISHED INFORMATION.

Contents

Robot Game Definitions and Rules2
Background Rules and Concepts2
Match Procedures5
Pre-Match Preparation5
Pre-Match Specifics5
Match Start6
Match Scoring.....7
After The Match8
Questions and Communications9
Robot Game Missions10
2008-09 FLL Mission Details10
Mission Scoring Diagrams12
Field Setup and Mission Models13
Field Mat Placement13
Using Dual Lock14
Model Details14
Field Maintenance.....16
Research Project17
Introduction17
The Project: Research, Create, Share.....18
The Project Resources19
Building the Table.....22
Materials.....22
Parts.....22
Assembly.....23

Robot Game Definitions and Rules

Background Rules and Concepts

Competition Values

- You are “Gracious Professionals” learning and competing like crazy, but treating one another with respect and kindness in the process.
- In the spirit of competitive innovation, as long as you’re not breaking any rules, there are no “wrong” or “unethical” strategies; only “allowable” and “reversible” strategies.

Participation

- The maximum allowable team size is ten members, not including coaches and mentors.
- See the *FIRST LEGO League Coaches’ Handbook* for allowable ages.
- At the tournament, only two team members at a time are allowed right up at the competition table except during repair emergencies.
- The rest of the team must stay back from the table, but close enough for different members to tag in or out as desired at any time. Specific positioning is decided by the head officials running each tournament.

Field

- The field is where the robot game takes place.
- It consists of a field mat, on a table, with mission models arranged on top.
- The field mat and the LEGO pieces for building the mission models are part of your Field Setup Kit.
- The instructions for building the mission models are on a CD, in the same box as the LEGO pieces.
- For all other field setup instructions see page 13.

Robot

- The robot is defined as the main body containing the NXT (or RCX) controller, and any currently installed parts or attachments, whether the installation is a press fit or a loose fit.
- Objects away from the robot are not part of the robot.

Strategic Objects

- Strategic objects are allowed and defined as team-supplied objects other than the robot.
- You may use a strategic object by hand to prepare or aim an inactive robot, but you must let go of it before the robot is allowed to start.
- An active robot may use a strategic object anywhere.

Mission

- A mission is something the robot can try to do on the field to score points.
- The robot starts completely in Base and goes out on one or more trips to work on one or more missions per trip.
- Missions may be tried in any order, alone or in groups, re-tried when possible and allowed, or skipped.
- Points are given if the required results are still visible on the field at the END of the match.

Match

- At a tournament, two Challenge fields are joined back to back, and each team is paired opposite another to compete in a match.
- For 2-1/2 minutes, the robot tries to get as many points as it can by achieving mission results.
- The timer never pauses during a match.
- There is a minimum of three matches, and each one is a fresh chance for you to get your best score.
- No match has anything to do with another, and only your best score counts specifically toward the Performance Award.

Round

- The process of cycling all teams through one match each is called a round.
- Tournaments run at least three rounds.
- Between your match in one round and the next, you usually have time to go to the pit area and work on the robot and its programs as needed, but this time may be limited, depending on the schedule of other proceedings.

Materials

This rule is not only about the robot. It is about everything you bring to the competition area.

- Everything you compete with must be made of LEGO elements in original factory condition, except LEGO string and tubing, which you may cut to length.
- There are no restrictions on the quantity or source of non-electric LEGO pieces, except that wind-up/pull-back “motors” are not allowed. Pneumatics are allowed.
- The electric elements used must be the LEGO MINDSTORMS type, and the total number of electric elements you may use in one match is limited as follows:

For RCX users:	For NXT users:
RCX controller (1)	NXT controller (1)
motors (3)	motors (3)
touch sensors (2)	touch sensors (2)
light sensors (2)	light sensors (2)
lamp (1)	lamp (1)
rotation sensors (3)	rotation sensors (3 minus the number of NXT motors present)
3 rd touch OR light sensor (1)	ultrasonic sensor (1)

- Example 1: If your robot has three motors, you may not have any other motor in the competition area, even if it's only for weight or decoration; even if it's in a box, off the field.
- Example 2: If your robot has two motors, but you have multiple attachments to motorize, you must design a way to switch the 3rd motor from one attachment to the next.
- LEGO wires and converter cables are allowed as needed.
- Spare/alternate electrical parts are allowed in the pit area.
- Objects functioning as remote controls are not allowed anywhere.
- Marker may be used for owner identification in hidden areas only.
- Paint, tape, glue, oil, etc. are not allowed.
- Stickers are not allowed except LEGO stickers applied per LEGO instructions.
- Note that it's a violation of this rule to use more than one robot in a single match, but it's okay to use a different robot in a different match.
- If a robot is in violation - of this rule or the SOFTWARE rule - and cannot be corrected, the decision about exactly what to do rests with the head officials at the tournament, but that robot may not win awards.

Software

- The robot must be programmed using LEGO MINDSTORMS, RoboLab, or NXT software (any release).
- Patches, add-ons, and new versions of the allowable software from the manufacturers (LEGO and National Instruments) are allowed.
- Text-based and/or “outside” software is not allowed.
- The point of this rule is the same as that of the MATERIALS rule: Since we can't ensure equal coaching for all teams, we can/must lessen this unfairness by capping the power of the tools.

Wireless Signals (At Tournaments Only)

- Downloading programs to robots is not allowed in the competition area.
- Teams downloading to an RCX robot must make sure the process is shielded, that there are no other RCX robots in range, and robots should be turned off when not in use.
- Teams downloading to an NXT robot must do so by cable. Bluetooth must be switched off at all times.

Base

- Base is an imaginary box formed by vertical walls that rise from the perimeter of the Base area, including the inside surface of the border walls, and by an invisible ceiling 16 in (40 cm) high.
- Base is a VOLUME—not an area.
- Base is the place for the robot to be prepared, started from, and serviced if needed.

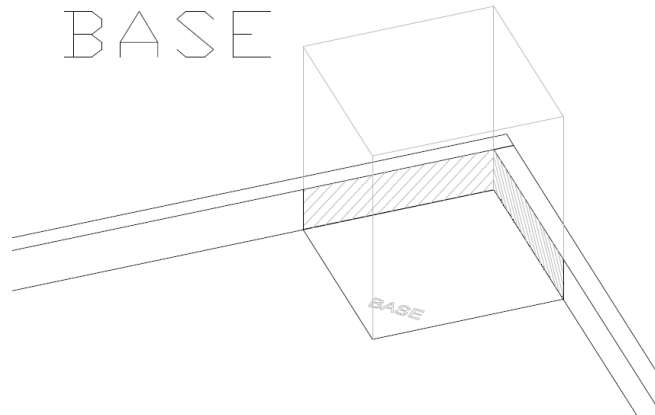

Housekeeping

- Objects in Base not currently being moved or used by the robot are okay for you to shift partially out of Base, out of the way, as long this action is not strategic in any way.
- Objects may also be held in hand or in a box by one of the two team members at the table.
- Objects eligible to score in Base should be placed in Base when the match is over so the ref can score them.
- Team members not at the table may not hold competition objects of any type.

Required Methods

Usually, no specific method is required for achieving mission results, and you are free/encouraged to be creative, but when a specific method *is* required for achieving a result, you must use that method or the ref will reverse the results.

If A Detail Isn't Mentioned, Then It Doesn't Matter

Assuming you have read all the missions, rules, and Q&A carefully...

- If no particular method is required, then any method is okay.
- If something is not required, then you don't have to do it.
- If there's no restriction against something, then it's allowed.
- There are no hidden requirements or restrictions.

Precedence

- When there is conflict between a mission and a rule, the mission takes precedence, but the current Q&A page on the web takes overall precedence. **MAKE SURE TO CHECK BACK THERE OFTEN.**
- The head ref is not obligated to consider calls made at previous tournaments unless those calls have been added to the latest Q&A.

Variability

As you build and program, keep in mind that our suppliers, donors, and volunteers make every effort to ensure that all fields are correct and identical, but you can expect some variability, such as:

- texture/bumps under the mat.
- waviness in the mat itself.
- flaws in the border walls.
- variety in lighting conditions.
- variety in light rigging and screw heads at the table ends.

You should direct questions about variable conditions at a particular tournament to that event's head officials.

Match Procedures

Pre-Match Preparation

- When you walk up to a field to compete on time, you're allowed at least one minute to prepare and arrange your inactive robot and any objects it will be moving or using.
- You must use the mission models supplied by the tournament and may not bring duplicates to the competition area.
- You may *NOT*:
 - take mission models apart.
 - lock or attach mission models to the robot.
 - lock or attach mission models to each other.
 - lock or attach anything to mission models.
 - touch mission models out of Base for any strategic purpose.
 - download anywhere near the competition area.

Pre-Match Specifics

The "Locked Or Attached" Test

- The ref must be able to pick up any single, non-Dual-Locked, mission model directly and freely, against no other force than gravity, and walk away with it, without any other object coming too...
- Or instead, the ref must be able to pick up the "other" object directly and freely, against no other force than gravity, and walk away with it, without the mission model coming too.



Muscle Action

- You may not cause anything but the robot to leave or extend even partially out of Base, except as described in the Start Procedure and Housekeeping rules.
- If something does leave Base against this rule, the ref simply puts it back.
- You may place objects completely in Base for an active robot to interact with, but only if you have obviously let go of them before the robot contacts them.
- However, dropping something on an active robot is considered an indirect touch and forces a restart.

Start Position

- For all starts and restarts throughout the match, every bit of the robot and any objects it is about to move or use must fit completely in the Base area.
- Nothing is allowed to be poking through the imaginary box of Base.
- The robot is allowed, but not required, to touch objects it is about to move or use.

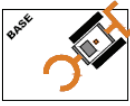
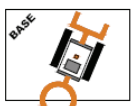
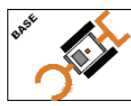
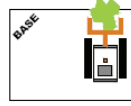
START POSITION

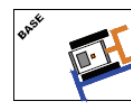
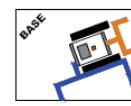
						
NO	NO	YES	NO	YES	NO	YES

Start Procedure

- To be ready to start, the robot must be motionless in start position, and you must not be touching it, or any object it is about to move or use.
- When this is plain to see, and you say you're ready, the referee (ref) will signal your field's readiness to the announcer. As the countdown starts, you may reach in with one hand, and at the exact start time, either touch a button, or signal a sensor, to start/resume the robot's program.
- You may not handle the robot, or anything it's about to move or use, during or after the countdown. If you do, the ref will have you restart. The point of this rule is to ensure that your only influence on the robot is to get its program running.

Match Start

Start Timing

- When teams and refs are ready, the announcer will provide a countdown, such as "Ready, set, GO!"
- The exact time to start is at the beginning of the last word in that phrase.
- If a different signal is used, the start is at the beginning of that signal.

Active Robot

At the moment the robot is started, it is considered "active" and remains so until you next touch it or touch any model or strategic object it is moving or using.

Active Robot Touched

- Any time you touch an active robot, or object it is moving or using, the robot is immediately considered "inactive" and must be carried to Base if it's not already there.
- The inactive robot in Base may then be handled, adjusted, reconfigured, and otherwise prepared as needed for restarting.
- If any models or strategic objects were being strategically moved by the robot at the time of the touch:
 - Those being moved from Base go back to Base with the robot, eligible for continued use.
 - Those encountered out of Base are taken out of play (off the field).
- Also, if the robot happens to be completely out of Base at the time of the touch, then a "touch penalty object" is taken out of play if one is available.
- Anything done by an inactive robot is reversed by the ref, to the extent possible, as soon as possible.

Loss Of Contact

If an untouched robot loses contact with an object, that object stays where it is unless/until the robot regains contact with it. Such objects may not be recovered by hand.

For exceptions, see the Stray Objects and Robot Damage rules.

Stray Objects

- An object caused by a robot to be in the way of either team's robot performance may be moved by the ref, upon team request, if that can be done without a direct effect on scoring.
- Objects in scoring position may be shifted by the ref to equivalent scoring positions if this can be done with no other strategic benefit, and worthless objects may be taken off the table.
- Objects in their original "setup" positions are not considered stray.

Robot Damage

At any time during a match, you may recover robot parts that come off as a result of obviously unintentional damage. You may do this by hand or request help from the ref.

Field Damage

- The robot is not allowed to break mission models or separate Dual Lock.
- If a mission model breaks, malfunctions, moves, or is activated by anything other than allowable action, the ref reverses the change as soon as possible (if possible).
- Field damage too severe to reverse is left as is and could fall under the Stray Objects rule.
- If points are earned along with field damage that occurs due to faulty model design, construction, or setup, you keep those points.
- Field damage that obviously occurs because of the team or robot, whether intentional or not, draws a warning. Repeats could make associated missions worthless.

Interference

- Your robot is not allowed to have any effect on the other team’s robot, field, or strategy except by directly meeting the scoring requirements of missions in areas that are shared between the two sides by design of the Challenge.
- There is always at least one mission where you and the opposing team are set up to interact in some way, either competitively or cooperatively.
- As a matter of luck, that team may be able to out perform you on that mission or may fail to cooperate with you there. This is not considered interference.

Match Scoring

Score Determination

- To minimize controversy about what happened during a Match, the score is determined* at the end of the match, by the condition of the field at that time only. *At the end of the match, the ref carefully examines the field to note the conditions and locations of objects.
- This means that points are not given for accomplishments that the robot accidentally trashes before the match ends, and this is why the ref reverses “illegal” results as they happen.

“In” (Operational Definition)

- A is “in” area B if any bit of A is over area B.
- Direct contact does not matter.
- Objects in a container are ruled individually and independent of their container.
- If an object’s location is hard to call, you get the benefit of the doubt.

IN

NO
 YES

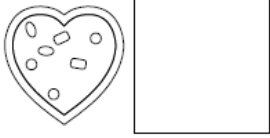

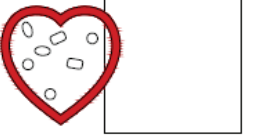





“On” (Operational Definition)

A is “on” B if either of these is true:

100% of A’s weight goes through B.

All objects diverting A’s weight around B could be removed without A falling (as tested or estimated by the ref).

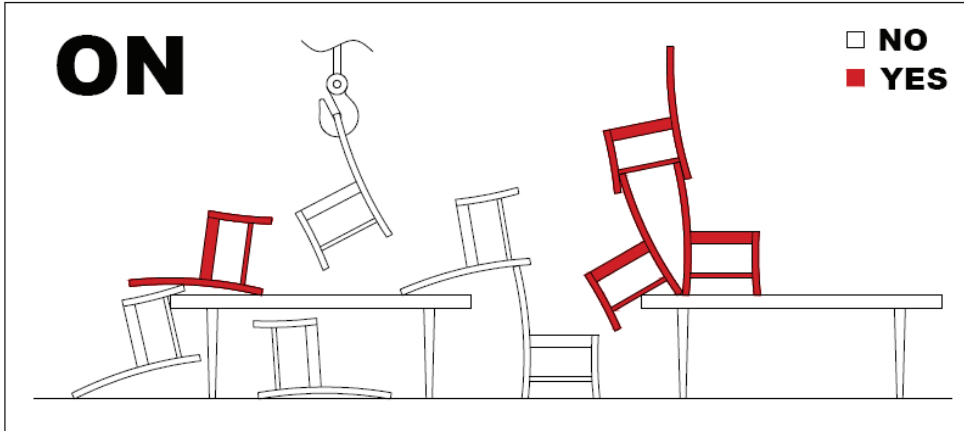

“Touching” (Operational Definition)

A is “touching” B if A is making direct contact with B.

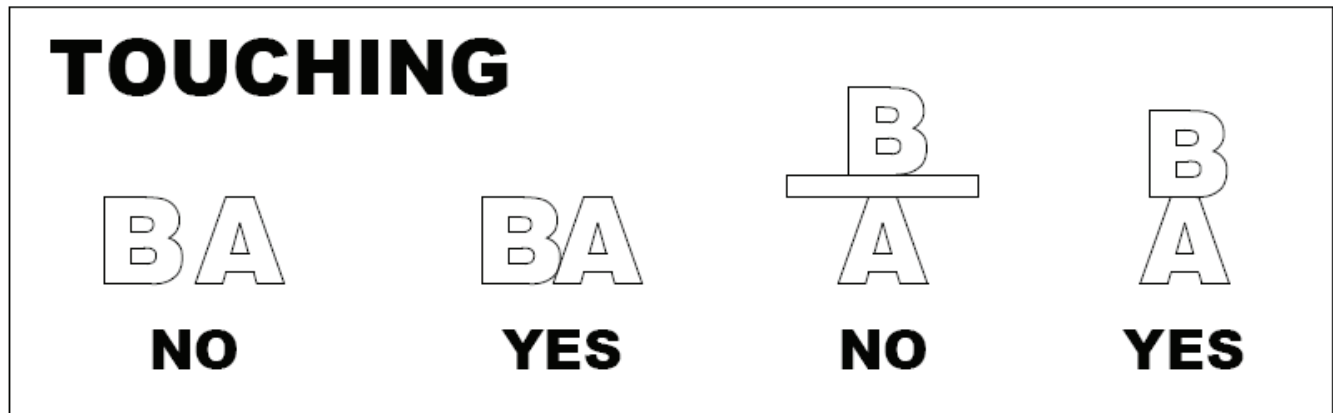

Benefit Of The Doubt

- You get the benefit of the doubt in situations that are too close to call, such as:
 - when a split-second or the thickness of a (thin) line is a factor.
 - when a situation could “go either way” due to confusing, conflicting, or missing information.
 - when anyone other than the challenge designer claims to know the “intent” of a requirement or constraint.
- If you disagree with the ref and can respectfully raise sufficient doubt in his/her mind, the ref meets with the head ref, and the resultant decision is final.
- This rule is not an order for the refs to be lenient, but it is a license for them to make judgment calls in your favor when it’s reasonable to do so.

After The Match

- At the end of each match, the ref needs time to concentrate and record the condition of the field, so no one is allowed to touch anything.
- You (kids only, please) and the ref look at the field together and come to agreement about what points were scored or missed and why, and to be sure you’re not walking away with any mission models.
- Finally, the ref gives the okay for field reset.

Questions and Communications

Challenge Questions/Support

- For official answers to questions about the Robot Game part of the Challenge, including rulings on special strategies or situations, e-mail filltech@usfirst.org (most efficient) or call 1-800-871-8326, x118 (less efficient).
- For best results, be sure you have read the four documents listed under READ THIS FIRST.
- When e-mailing, be sure to put "Challenge" in the subject line, and please state your role on the team (member, coach, parent, mentor).
- When calling, please first leave your contact information slowly, your role on the team, and YOUR QUESTION on voicemail.
- filltech does not answer questions about building or programming the robot (that's your Challenge).
- filltech can not support LEGO product.
- For NON-game-related technical support for LEGO product (RIS, RoboLab, NXT), call 1-866-349-5346.
- The FLL International Forum is great for sharing ideas and getting tips from each other, but it is NOT AN OFFICIAL SOURCE OF ANSWERS about anything.

Information Sharing And Consistency

- Since individual victory need not come at the expense of collective excellence, all official answers given through Challenge support are subject to public posting in the Q&A, including answers about ALLOWABLE strategies.
- Also, the only documents given to the refs for reference to conduct matches and make calls are the same four documents you and every other team have access to all season.
- If a strategy is questionable for you, chances are it will be questionable for the ref too, and guarding it until the tournament is risky.
- No new Q&A entries will be posted after 3PM (eastern U.S.) on Fridays.

Coaches' Meeting

- If a question does come up right before the tournament, your last chance to ask it is at the "Coaches' Meeting" (if there is one) the morning of the tournament.
- The head ref and coaches meet to identify and settle any differences **before** any matches start.
- For the rest of the day, the ref's calls are final when you leave the table.

Summary Of Significant Content Changes For 2008

- New Competition Values rule - sets the moral tone for competition and good will to co-exist.
- Participation rule - now expressly allows tagging in/out.
- Start Position rule - shows that it is now okay for an aiming jig to be left in place during starting.
- Start Procedure rule - now allows the robot to contact/interact with strategic objects while leaving Base, and does not require the robot to leave Base.
- New Start Timing rule - promotes precision/consistency/fairness
- New Active Robot rule - substitutes a hand-input as the start of autonomy instead of the robot being completely out of Base as the start of autonomy. It also replaces preparation, transition, and autonomy modes with "active" or "inactive."
- New Active Robot Touched rule - eliminates placement-by-touch and retrieval-by-touch loopholes.
- Strategic Objects rule - now explicitly allows the robot to use strategic objects in Base.
- Materials rule - now excludes wind-up/pull-back motors.
- Housekeeping rule - now requires Base-scoring objects to be in Base at the end of the match and it also rules that only the two team members at the table can hold objects.

Robot Game Missions

2008-09 FLL Mission Details

→ Be sure to review the mission diagrams on page 12.

Bury Carbon Dioxide (Carbon Sequestration)

Move carbon dioxide (the gray balls) to the underground reservoir. For each carbon dioxide to score, it must be touching the reservoir model and/or the mat within the model, but it must not be touching the mat outside the model. Scoring carbon dioxide (balls) are worth **5** points each.

Construct Levees

Move levee blocks to low-lying shores while being careful not to damage the ones that are already in scoring position... For each block to score, it must be upright and touching low-lying shores on the mat. Scoring blocks are worth **5** points touching red and **4** points touching green. Blocks touching both red and green shores are scored as touching red only.

NOTE: Levee blocks are this year's "touch penalty objects." When an active robot is touched while it's completely out of Base, the referee will take one levee block off the field, out of play, starting with those that are in Base. If there are none in Base, the one currently farthest west in the field will be taken. If the only levee blocks available are being moved by the robot at the time of the touch, one of those will be taken after the robot is carried back to Base. If all 8 levee blocks have been taken already, there is no loss.

Test Levees

See how levees survive when a storm approaches (activate the wheel-roller). The wheel must be allowed to roll freely until it either hits or misses the levees. The activation is worth **15** points whether the levees are hit or missed, but worth no points if the wheel is strategically blocked by anything other than released levees near or past the green shore.

Raise The Flood Barrier

The barrier in the up position (red lever down) is worth **15** points.

Elevate The House

The house in the up position (red lever east) is worth **25** points.

Turn Off The Lights

The window showing black is worth **20** points.

Open A Window

The window all the way open is worth **25** points.

Get People Together

Three or more red/white citizens touching the pink grid area is worth **10** points.

Three or more blue/gray leaders touching the tall, green mountain and/or city is worth **10** points.

Three or more black/white scientists touching the research area is worth **10** points.

Find Agreement (Align The Arrows)

Before the match starts, the referee sets the yellow arrows in random disagreement. Alignment of both yellow arrows is worth **40** points for both teams, no matter which direction the alignment faces and no matter if one or both robots helped.

Fund Research Or Corrective Action

Move money (the yellow ball) to the research area or to the underground reservoir. For the ball to score, it must be touching the underground reservoir or research area (ice sheet) models and/or the mat within those models, but it must not be touching the mat outside those models. The scoring money is worth **15** points.



Deliver An Ice Core Drilling Machine

Move the core drilling machine to the research area. For the machine to score, it must be making direct contact with the research area model and/or the mat within that model, but it must not be touching the mat outside that model. The scoring machine is worth **20** points. The drill assembly raised completely vertical is worth an additional **10** points.

Extract An Ice Core Sample

The ice core pulled completely from its hole is worth **20** points. The ice core in Base is worth an additional **10** points.

Deliver An Ice Buoy

Move the ice buoy to the research area. For the buoy to score, it must be upright and making direct contact with the research area model and/or the mat within that model, but it must not be touching the mat outside that model. The scoring buoy is worth **25** points.

Insulate A House

Move the insulation to the green grid area. *Both* insulation touching the green grid area is worth **10** points.

Ride A Bicycle

Move the bicycle to the green grid area. The bicycle touching the green grid area is worth **10** points.

Telecommute And Research

Move the computer to the green grid area. The computer touching the green grid area is worth **10** points.

Study Wildlife

Move the polar bear and/or the snowmobile to the research area. To score, they must be making direct contact with the research area model and/or the mat within that model, but they must not be touching the mat outside that model. The scoring bear is worth **15** points upright, or **10** points "sleeping" (on its side), and the scoring snowmobile is worth **10** points.

Beat the Clock

At the end of the match, if the robot is making direct contact with the research area model and/or the mat within that model, but it's not touching the mat outside that model, that's worth **15** points. –OR– At the end of the match, the robot touching only the yellow grid area is worth **10** points.

Mission Scoring Diagrams

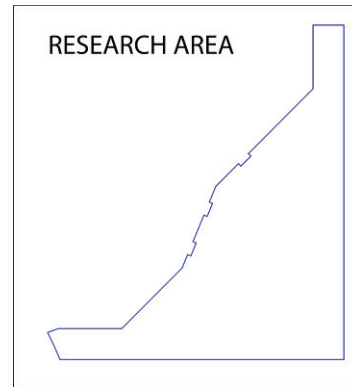
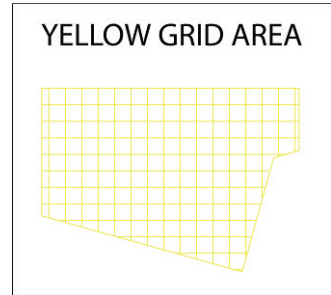
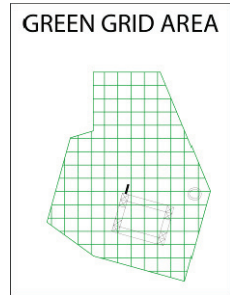
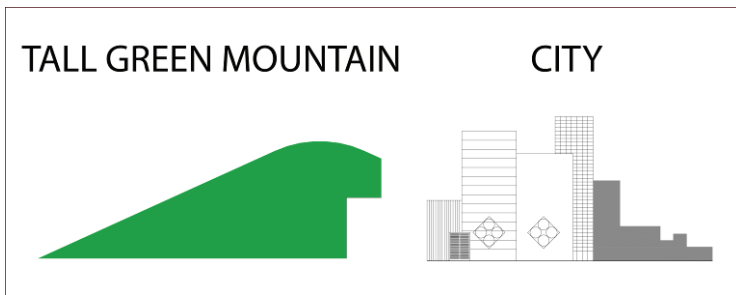
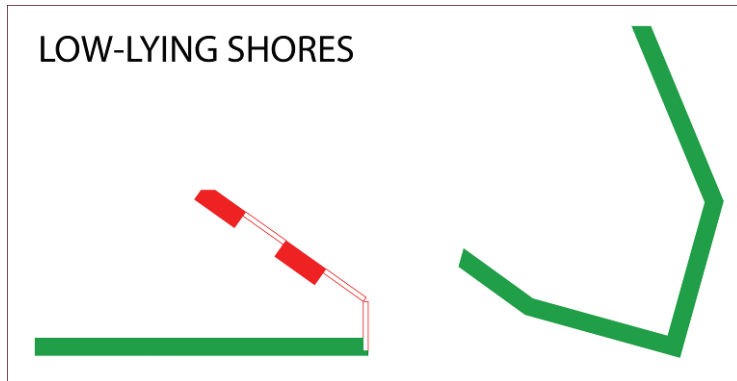
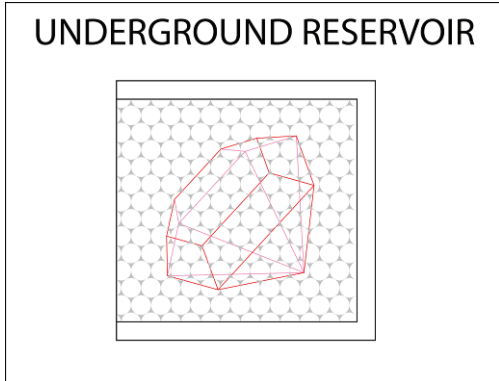

AGREEMENT

DISAGREEMENT

Field Setup and Mission Models

Field Mat Placement

Step 1 Vacuum the table top. Even the tiniest particle under the mat can give the robot trouble. After vacuuming, run your hand over the surface and sand or file down any protruding imperfections you find. Then vacuum again.

Step 2 On the vacuumed surface (never unroll the mat in an area where it could pick up particles), unroll the mat and position it so the image is up and BASE (the area with logos) is at the southwest of your surface (the south edge should be one you have easiest access to).

Step 3 Slide and align the mat so that there is no gap between the southwest corner's edges of the mat and the corresponding southeast border walls. Gaps are expected and acceptable at the north and east edges.

Step 4 With help from another person, pull the mat at opposite ends, then massage out any waviness from west to east and re-check the requirement of Step 3. It is expected that some waviness will persist, but that should relax over time. Some teams use a hair dryer to speed the relaxation of the waviness.

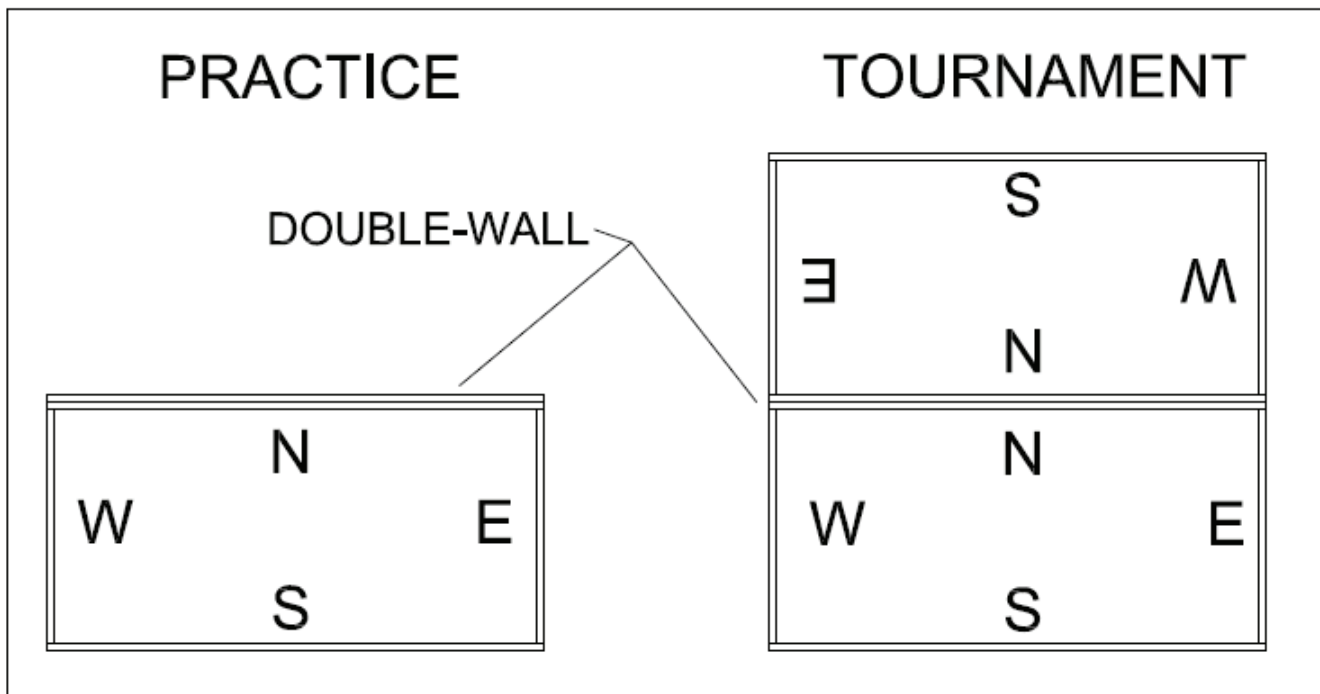

Using Dual Lock

The Mission Models can be taken off the field mat for transport and storage. Some are loose, but others are secured using a re-usable fastening material from 3M called Dual Lock, which comes with the LEGO bricks in your Mission Model Set. Dual Lock is designed to stick or “lock” to itself when two faces of it are pressed together, but you can unlock it too.

When a model’s placement requires Dual Lock, the model’s location mark on the mat will contain boxes with X in them. For each X box, apply a piece of Dual Lock, adhesive side down, to the mat. Square pieces will need to be cut in half for any half-sized boxes. Next, press (lock) a like-sized piece of Dual Lock, adhesive side up, onto to the ones you just finished sticking to the mat.

Tip: Since the second piece of each Dual Lock pair would rather stick to you than lock to its partner, press the second piece onto the first using the wax paper the Dual Lock was supplied on instead of your bare finger, then peel away the paper.

Finally, for each Dual Locked model, line the model up exactly over its location, being sure that all labeled features are facing as labeled. Carefully lower the model and press it down onto the Dual Lock. Try to press down on the lowest solid structure of each model instead of crushing the whole model. This application process for the Dual Lock is only needed once—later, the models can simply be locked onto the mat or unlocked.

Model Details

Levee Blocks (No Dual Lock) There are eight levee blocks. Five go in Base (anywhere), and for the remaining three, each one is centered upright on one of the thin red rectangle outlines bordering the purple grid area.

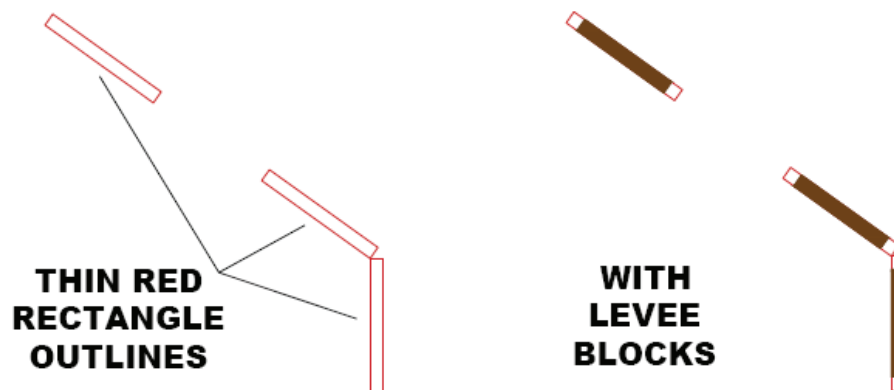

Storm (Wheel Roller) Place Dual Lock on its marks, position this model as shown on the mat, and stick it down. Operation: When the perimeter bar is triggered, the vertical axle slides down, releasing the hammer (black hinged part) to fall, pushing the wheel out. Setup: Lift the hammer until you can poke the vertical axle through its catch hole, and slowly let go of both. When that’s done, carefully place the wheel over its image on the mat (No Dual Lock). This is designed to be an unstable setup, but it does work consistently when the model is built, placed, set, and maintained correctly. Make sure the hammer falls freely. If it doesn’t, check to be sure there’s free play along the hinge axle, that the red beams are parallel, and that they give the hammer clearance, and finally, be sure there’s no Dual Lock touching the hammer.

People (No Dual Lock) There are six people. Those with black, blue, or red shirts go in Base (anywhere). Those with black pants go on their marks in the research area, with their ski poles generally downward. Those with blue pants sit on their marks on the buildings, partly facing north, and each other. Those with red pants are press-fit to stand on the northeast corner of the underground reservoir model, over their marks. Take note of where their marks are, because they will be covered out of view later. As long as people of a certain clothing are together where they

need to be, their individual right/left placement is random (faces and hair are not considered), but their hands should be near their pockets.

Underground Reservoir Before you proceed, notice that the northeast corner of the location mark for this model also has location marks for standing people. Memorize where those marks are, because you're about to cover them... Place Dual Lock on its marks, position this model as shown on the mat, and stick it down.

Ice Sheet This model had to be changed after the mat went into production, so it does not line up perfectly with its location marks. Without Dual Lock, place each segment, one at a time, on its mark, to see where the Dual-Lock location marks miss the model, and shift the Dual Lock as needed for full contact. With the new/correct Dual Lock locations in mind, place Dual Lock as needed, position the first segment, and stick it down. For each next segment, make sure it's completely connected to the last one before sticking it down. Finally, place the ice core (little red loopy model) (no Dual Lock) in its hole with its loop running parallel to the east border wall.

House Place Dual Lock on its marks, position this model as shown on the mat, and stick it down. Setup: The house should be in the down position, with its large lever toward the west. Twist the wheel fully clockwise to close the south window. Twist the little red knob fully clockwise and pull it outward to set the lights "on" in the north window.

Cross-Pointers (Interactive Models) Your table should have two border walls back to back at the north. Find the absolute center of these two walls. In the north/south direction, this point is the "crack" where the two walls touch. In the east/west direction, this point is 46.5in. (118.1cm) from the inside face of either far wall. Now measure east and west of this center point, 11in. (27.9cm) each way. Each of these new points is the center point for one of the cross-pointer models. Cover the underside of each model's foot completely with Dual Lock, align it and its rubber band parallel to the borders, and stick it down. If it does not sit level, add Dual Lock on the low side to level it. Setup: Spin each arrow to a random direction. Any direction for either arrow is okay as long as the arrows do not agree with each other.

Flood Gate This model had to be changed after the mat was produced, so it does not line up perfectly with its location marks. The west side is good, so use that as normal, but for the east side, apply Dual Lock to the model instead of the mat. Align the east side as accurate as possible, and stick it down.

Carbon Dioxide And Money (No Dual Lock) There are four carbon dioxides (gray balls), and one money (yellow ball), and a holder (thin tire) for each. Place a tire on each tire location mark, and place a gray ball on each tire in the water, and the yellow ball on the tire in the green grid area.

Core Drilling Rig (No Dual Lock) Place this model on its location mark with direction as shown on the mat. Setup: The drill assembly part should be down/level.

Bicycle, Ice Buoy, Laptop, And Insulation (No Dual Lock) Place the bicycle, ice buoy, and laptop on their location marks, with directions of the bicycle and laptop as shown on the mat. Place the insulation (both) on its mark, one aligned on top of the other.

Bear And Snowmobile (No Dual Lock) Place the bear and snowmobile in Base (anywhere) with the five levee blocks and six people that are already there.

Field Maintenance

- **Border Walls** Remove any obvious splinters, and cover any obvious holes.
- **Field Mat** Make sure the mat rests evenly at the bottom of the south and east border walls. Avoid cleaning the mat with anything that will leave a residue. Any residue, sticky or slippery, will affect the robot's performance compared to a new mat (many tournaments use new mats). Use a vacuum and/or a damp cloth for dust and debris (above and below the mat). When moving the mat for transport and storage, be sure not to let the material bend into a sharp kink point, which could affect the robot's movement. Many consistent repetitions of rubbing on the same areas of your practice mat should be expected to cause wear in the image, but such wear is unlikely at a tournament. Tournaments using new mats should unroll the mats as far in advance of the tournament day as possible. For control of extreme curl at the east or west edges of the mat, tape is allowed, with a maximum of $\frac{1}{4}$ " (6 mm) overlap. Do not use tape under the mat.
- **Mission Models** Keep the models in original condition by straightening and tightening solid connections often. Ensure that spinning axles spin freely by checking for end-to-end play and replacing any that are bent.



Research Project

Introduction

The exploration of the Challenge theme and the development of a research project is a critical part of the overall FLL experience. FLL is not just about building and competing with robots. *FIRST* encourages well-rounded teams because any successful engineering project requires a wide variety of skills.

Through the project research, teams learn more about the science behind the Challenge theme and better understand the work of professionals in that field. Teams will encounter challenges similar to those faced by scientists and engineers as they identify a problem and develop an innovative solution. Exposure to these fields of science and related professions open kids' eyes to future career choices where they can make a positive difference to society.

NOTE: In order to be eligible for project awards at qualifying and championship tournaments, your presentation must explain how you completed *all three parts* of the project:

- *identify* a problem,
- *create* a solution,
- *share*

Consult the Project Rubric in the *FIRST LEGO League Coach's Handbook* for more information. The total length of your project presentation should be no more than five minutes, including any set-up time.

Weather is the condition of the atmosphere measured in short lengths of time (hours and days). Climate, however, is the average weather over decades and centuries in a specific location. We can look out our window and see how weather changes every day, but we need data that has been tracked over hundreds of years to understand how the climate may be changing.

Climate tracking is important to communities around the world because the information is used to plan, predict, and make decisions on activities like planting crops or hunting and fishing. People also use data to anticipate the impacts of climate on the economy, food and water availability, tourism, disease control, and many environmental issues.

Why is climate important to us? By gaining a greater understanding of the Earth's complex climate systems, we will be able to work together now and in the future to develop the innovative solutions that will benefit us all and continue to improve the world in which we live.

Can FLL teams make the necessary Climate Connections?



The Project: Research, Create, Share

1. **Research how climate affects your own community.** Identify a climate problem in your area, analyze climate data about the problem, and discover what your community is doing about it. Find another community somewhere in the world with the same issue and identify any solutions they are working on.

Discuss the various ways climate impacts your community and your lives. Look at climate data available for your area as it relates to your climate problem. Consider talking with experts who work in a climate-related profession every day, such as climatologists, farmers, foresters, and community leaders. Then find another community in a different geographical area that is experiencing a similar problem. Consult the FLL Topic Guide for additional project resources.

2. **Create an innovative solution based on the information you gathered.** See if others, on a local or even global level, could use your innovation to solve this climate problem or improve on an existing solution.

Consider all the potential solutions to your climate problem and how great an impact you can have. Talk with experts to see what ideas are already being developed or used. Build your climate connections by creating an innovative solution for your chosen climate problem that could be applied in both communities and adopted by even more communities who face a similar issue.

3. **Share your research and solution.** Once you have researched and developed your idea, get out there and share it! Take what you have learned to build awareness of the problem and promote your solution, highlighting your research. Use this project to see just how great an impact you can have on your community and your world!



The Project Resources

These resources are intended to help you with your FLL project, but are not a substitute for following the project guidelines for the current season. Click [\[here\]](#) for the project guidelines.

If you choose to refer to them, the following guides and activities are resources readily available to help you complete your project. Your team will enjoy finding many other resources on its own, so you can consider these a starting point to help get your team going.

(the following list should be bookmark/anchor links)

- Glossary of Common Terms
- *Project How-To Guide*
- Talking with Experts
- Challenge-Related Activities & Information
- Web Resources

Glossary of Common Terms for Climate Connections [PDF]

***Project How-To Guide* [PDF]**

The exploration of the Challenge Project is critical to the overall FLL experience. FLL is not just about building and competing with robots. *FIRST* encourages well-rounded teams. This document will help your team break the project down into smaller, more manageable parts to get started.

Talking with Experts – Preparation Ideas and Sample Interview Questions [PDF]

Talking with experts who work in the field of the Challenge theme is a great way for your FLL team to learn more about the topic, find out current data, discover potential problems, and learn what is being done about those problems. This guide will help you get started.

Challenge-Related Activities & Information

These pages will provide your team with additional information and activities that relate to Climate Connections. Use them to supplement and/or jump-start your project research.

Print individual activities and info sheets by selecting from the list below:

- * Levee building activity [PDF]
- * Glacier melting activity [PDF]
- * Carbon Sequestration [PDF]
- * Ice cores and Ice Buoys [PDF]
- * Atmospheric CO2 levels activity [PDF]

We have also collected a number of activities and lesson plans available online this year.

- * Resources for teachers [PDF]

Web Resources

There are an infinite number of web resources available to teams. Rather than attempt to provide them all, we have selected some and have provided search terms you might use to find sites of your own. The following links are intended to help you get started. We highly recommend searching for web sites, books, magazines, and other sources of information that apply directly to your project topic. Successful teams will gather information from a wide variety of sources. Don't forget to visit your public library!

Fun & Interactive Sites

Climate change game from the BBC

http://www.bbc.co.uk/sn/hottopics/climatechange/climate_challenge/

Earth Day Footprint Quiz - an interesting activity for kids to try on their global footprint

<http://www.earthday.net/Footprint/index.asp>

EPA Global Warming Kids Site: Focuses on science and impacts of global warming or climate change and on actions that help address global warming

<http://epa.gov/climatechange/kids/index.html>

General information about climate and weather

<http://www.weatherwizkids.com/climate.htm>

Climate Change Club Web site from the conservation corps of Newfoundland and Labrador

<http://www.conservationcorps.nf.ca/cccl/index.html>

Game from IBM and TryScience/NY Hall of Science

<http://www.powerupthegame.org/>

A site created by WGBH about green living and sustainability

<http://www.meethegreens.org/>

An article about how making decisions that reduce your carbon footprint is a great way for kids to get involved in reducing the impacts of climate change

<http://www.timeforkids.com/TFK/kids/specials/articles/1,28285,1613313,00.html>

Search terms: climate plus anything from the glossary of terms, plus carbon footprint, data, game, kids

Climate Change Skepticism

List of climate change skeptics

http://www.sourcwatch.org/index.php?title=Climate_change_skeptics

Article about a recent conference

<http://www.realclimate.org/index.php/archives/2008/01/what-if-you-held-a-conference-and-no-real-scientists-came/>

A site encouraging debate and discussion about climate

<http://www.demanddebate.com/>

Search terms: climate plus skeptics, global warming, climate change

Scientists & Their Research

Byrd Polar Research Center - studies of various ice core drilling expeditions around the world

<http://bprc.osu.edu/Icecore/front-page.html>



Notes from the field – a polar scientist talks about a research mission he participated in

<http://www.mcgill.ca/reporter/40/07/notes/>

Julie Brigham-Grette (2008 FLL Game Challenge Consultant) shares information about her career and research

<http://www.geo.umass.edu/faculty/jbg>

NASA's Jet Propulsion Lab Polar Playground Ice Buoy: The Argos Buoy is shown on deformed seasonal sea ice in the Weddell Sea

<http://southport.jpl.nasa.gov/polar/toys.html>

A great resource including the science around climate change, the impact, and solutions

http://www.davidsuzuki.org/Climate_Change/

Links climate change to energy consumption

<http://www.iisd.org/climate/>

What is Causing the Dramatic Decline in Honeybee Populations in the U.S. & Elsewhere in Recent Years?

http://www.organicconsumers.org/articles/article_5485.cfm

Access to a wealth of Earth science data sets.

<http://viz.globe.gov>

Search terms: climate plus habitat, data, migration patterns, research, scientists

Climate Data, Governments, & Policy

Find climate data

<http://www.worldclimate.com/>

<http://outflux.net/weather/noaa/>

<http://www.BestPlaces.net/climate/>

Learn more about the concepts of latitude and longitude and find locations around the world

<http://www.socialstudiesforkids.com/subjects/latitudelongitude.htm>

Climate data from around the U.S.

<http://lwf.ncdc.noaa.gov/oa/climate/research/ushcn/ushcn.html>

Site from Environment Canada includes a report on the status of emissions and plans to curb them

<http://www.ec.gc.ca/climate/home-e.html>

The Intergovernmental Panel on Climate Change is the Nobel winning, international collaboration that has objectively studied and reported on all aspects of climate change.

<http://www.ipcc.ch/>

The NASA Earth Observatory includes data, images, experiments, missions, and much more.

<http://earthobservatory.nasa.gov/>

EPA's Climate Change Page: This is a wide-ranging overview of climate change, from science to policy.

<http://epa.gov/climatechange/index.html>

Search terms: climate plus policy, data, government, collaboration

Building the Table

The robot game takes place on a specially designed table, so you'll need to build one to practice on if you don't already have access to one. With safety, weight, height, and cost in mind, a simple design is offered here, but as long as your surface is smooth, and your border walls are located properly, how you build the understructure is up to you. The construction is simple, but does require some shop skills. Build the light onto your table if your table will be placed in poor and/or variable lighting conditions.

At a tournament, two tables are placed back to back, forming a double-thick border between them. Since accurate setup requires that double-thick border, you're instructed to build it onto your practice table by adding a second one behind the first.

Materials

Material	Quantity (with light)	Quantity (no light)
Field Setup Kit	1	1
smooth plywood 96" X 48" X 1/4"	1	1
two-by-four, 8'	4	4
two-by-three, 8'	3	2
two-by-three, 10'	1	N/A
flat black paint	1 pt. or spray can	1 pt. or spray can
coarse drywall screws, 6 X 2-1/2"	1/2 lb.	1/2 lb.
saw horses, about 24" high and 36" wide	2	2
48" fluorescent shop light w/(2) 40-watt tubes	1	N/A

Parts

Part	Make From	Dimensions	Paint	Quantity (with light)	Quantity (no light)
table surface	plywood	96" X 48"	no	1	1
long border wall	two-by-four	96"	yes	3	3
short border wall	two-by-four	45"	yes	2	2
stiffener	two-by-three	48"	no	4	4
upright	two-by-three	48"	yes	2	N/A
cross beam	two-by-three	99"	yes	1	N/A
saw horse	kit	H \approx 24" W \approx 36"	no	2	2

Assembly

Step 1 Determine which face of the plywood is least smooth, and consider that the bottom face. On the bottom face, locate, clamp, and screw on the stiffeners (about every 18 inches).

Step 2 On the top face of the plywood, locate and clamp the border walls around the top perimeter. The wall-to-wall dimensions are important; they need to measure 93" by 45".

Step 3 With the help of another person, place this table top on short saw horses (or milk crates, or anything else short and solid).

Step 4 If you're adding the light, center, clamp, level, and screw the uprights onto the outside face of the short border walls. With the help of another person, situate the cross beam on top of the two uprights and screw it down. Hang the shop light by its chains from the center of the cross beam. Tie some rope or a zip-tie loosely around the center of the shop light to hold the bulbs from falling if they were to become loose.

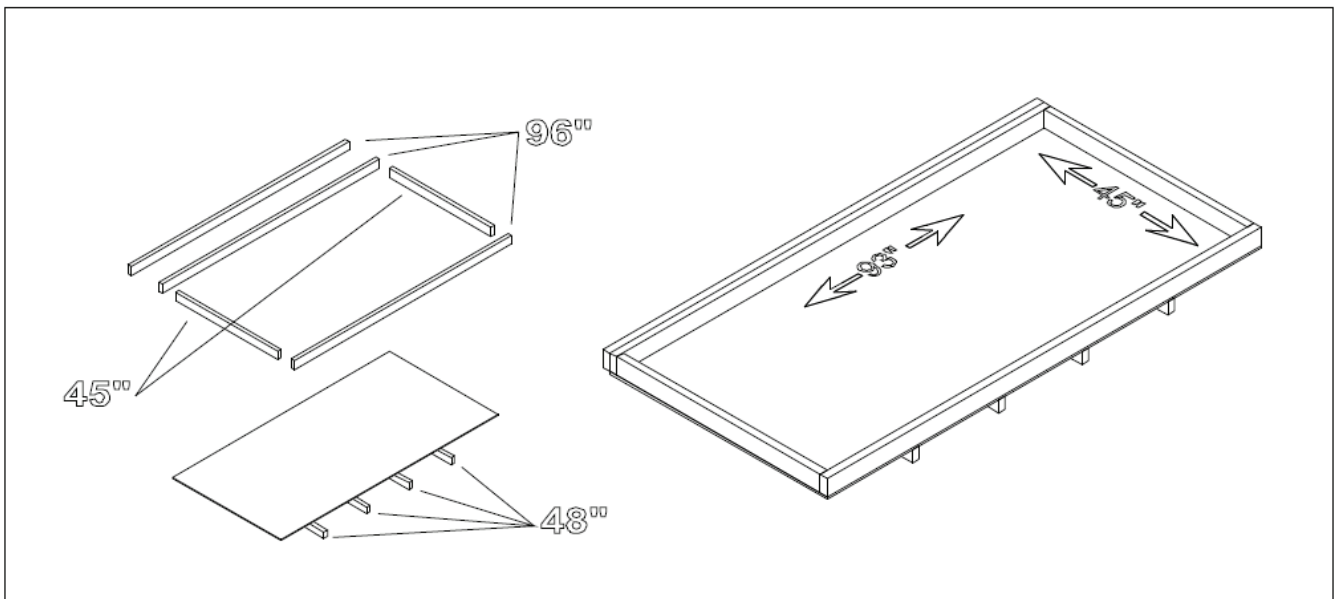

PRACTICE TABLE

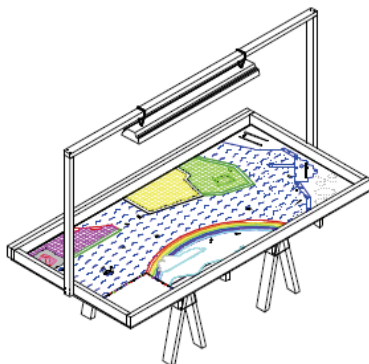

TOURNAMENT TABLE

